

Sydney Office:  
512 Miles Street  
Bankstown Airport, NSW, 2200

Telephone: 02 9793 9900  
Fax: 02 9793 9099  
Email: [sydney@aeroengaus.com.au](mailto:sydney@aeroengaus.com.au)



ABN 52 881 341 225  
[www.aeroengaus.com.au](http://www.aeroengaus.com.au)

---

Report: AV13697.003/51  
Title: Installation Plan - Indigo One Tracking System – DHC-2  
Aircraft: De Havilland Canada DHC-2 Beaver

Issue: Issue 1  
Date: 1<sup>st</sup> June 2009

Prepared: N. Levchenko Date: 1/6/09

Checked by:   
L. Ramirez Date: 1/6/09

PREPARED: N. Levchenko CHECKED: L. Ramirez ISSUE No.: One	<b>AERONAUTICAL ENGINEERS AUSTRALIA</b>	PAGE No.: Page 2 of 9 REPORT No.: AV13697.003/51 FILE: Installation Plan DHC-2.doc
<b>Installation Plan - Indigo One Tracking System – DHC-2 Beaver</b>		

## LOG OF REVISIONS

<u>Issue</u>	<u>Date</u>	<u>Pages</u>	<u>Description</u>
1	1 June 2009	Pages 1 to 9	Original issue

PREPARED: N. Levchenko CHECKED: L. Ramirez ISSUE No.: One	<b>AERONAUTICAL ENGINEERS AUSTRALIA</b>	PAGE No.: Page 3 of 9 REPORT No.: AV13697.003/51 FILE: Installation Plan DHC-2.doc
Installation Plan - Indigo One Tracking System – DHC-2 Beaver		

## CONTENTS:

<b>1.</b>	<b>INTRODUCTION .....</b>	<b>4</b>
<b>2.</b>	<b>INSTALLATION PLANNING.....</b>	<b>4</b>
2.1.	Select Antenna Position.....	4
2.2.	Select a Panel Position for the Panel Control Unit .....	5
<b>3.</b>	<b>INSTALLATION DETAILS .....</b>	<b>6</b>
3.1.	Install the Antenna .....	6
3.2.	Antenna Cable Routing.....	7
3.3.	Wiring Harness Installation Procedure.....	7
3.4.	Install the Panel Control Unit .....	7
<b>4.</b>	<b>FUNCTIONAL TESTING .....</b>	<b>7</b>
<b>5.</b>	<b>EMI / EMC TESTING.....</b>	<b>8</b>
<b>6.</b>	<b>POST INSTALLATION.....</b>	<b>9</b>
<b>7.</b>	<b>USER MANUAL .....</b>	<b>9</b>
<b>8.</b>	<b>ONGOING AIRWORTHINESS.....</b>	<b>9</b>
<b>9.</b>	<b>STANDARD NOTES .....</b>	<b>9</b>

## 1. INTRODUCTION

This installation plan outlines the basic elements to be considered for the Indigo One Tracking and Communication System Installation in de Havilland Canada DHC-2 Beaver aircraft.

This plan should be read in conjunction with the IndigoSat Installation Manual, Document Number IS-IM-2008-002, Revision A (or later revision) which provides further details pertinent to the installation of the Indigo One system.

## 2. INSTALLATION PLANNING

### 2.1. Select Antenna Position

Select an appropriate antenna location based on the area suggested in Figure 1 below. The antenna should occupy a vacant skin panel on the cabin roof surrounded by a fuselage frame and stringer and be separated from existing antennas by the distances specified in the IndigoSat Installation Manual (IS-IM-2008-002)

Note that aircraft fitted with a WAAS GPS system (eg. GNS430W or GNS530W) have been found to be sensitive to Indigo One antenna placement. Generally, a distance of approximately 3.0 m (10ft) is required between a WAAS antenna and the Indigo One antenna to prevent interference, requiring a position outside of the region indicated below.

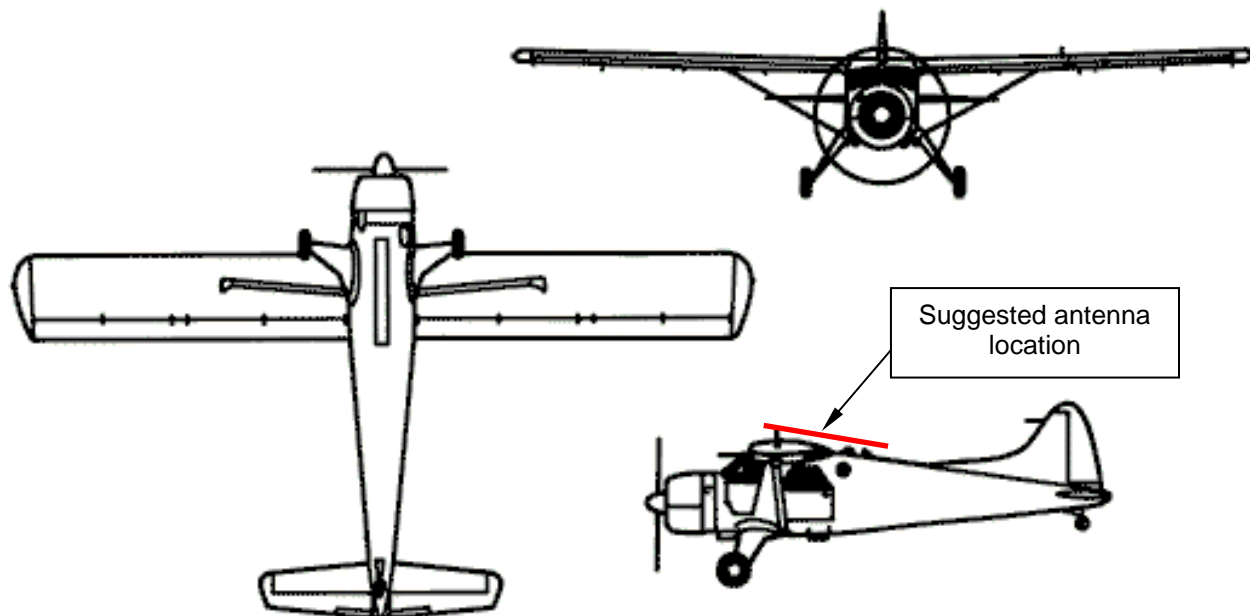

**Figure 1. Suggested location of Indigo antenna**

## 2.2. Select a Panel Position for the Panel Control Unit

Select an appropriate vacant space in the cockpit for the installation of the Indigo display unit. The Indigo One cradle supplied with the kit fits in a standard 6.25” avionics rack.

There are several possible positions for location of the Indigo One control unit on the flight deck of the DHC-2. The operator or installer may be in the best position to specify where they wish it located based on available space, operational considerations and ease of access for installation. Depending on position chosen and availability of existing avionic rack structure, additional support structure to hold the cradle may be necessary. No pilot access to the unit is required for proper operation of the tracking system.



***Figure 2. Suggested locations of display unit***

### 3. INSTALLATION DETAILS

#### 3.1. Install the Antenna

Figure 3 provides the template for hole pattern and size required for the coaxial cable connection to the antenna and the antenna attachment. When mounting the antenna, cover the bottom of the antenna with PR1422 or a MIL-A-56106A silicone sealant.

Refer to the IndigoSat Installation Manual (IS-IM-2008-002) for further information.

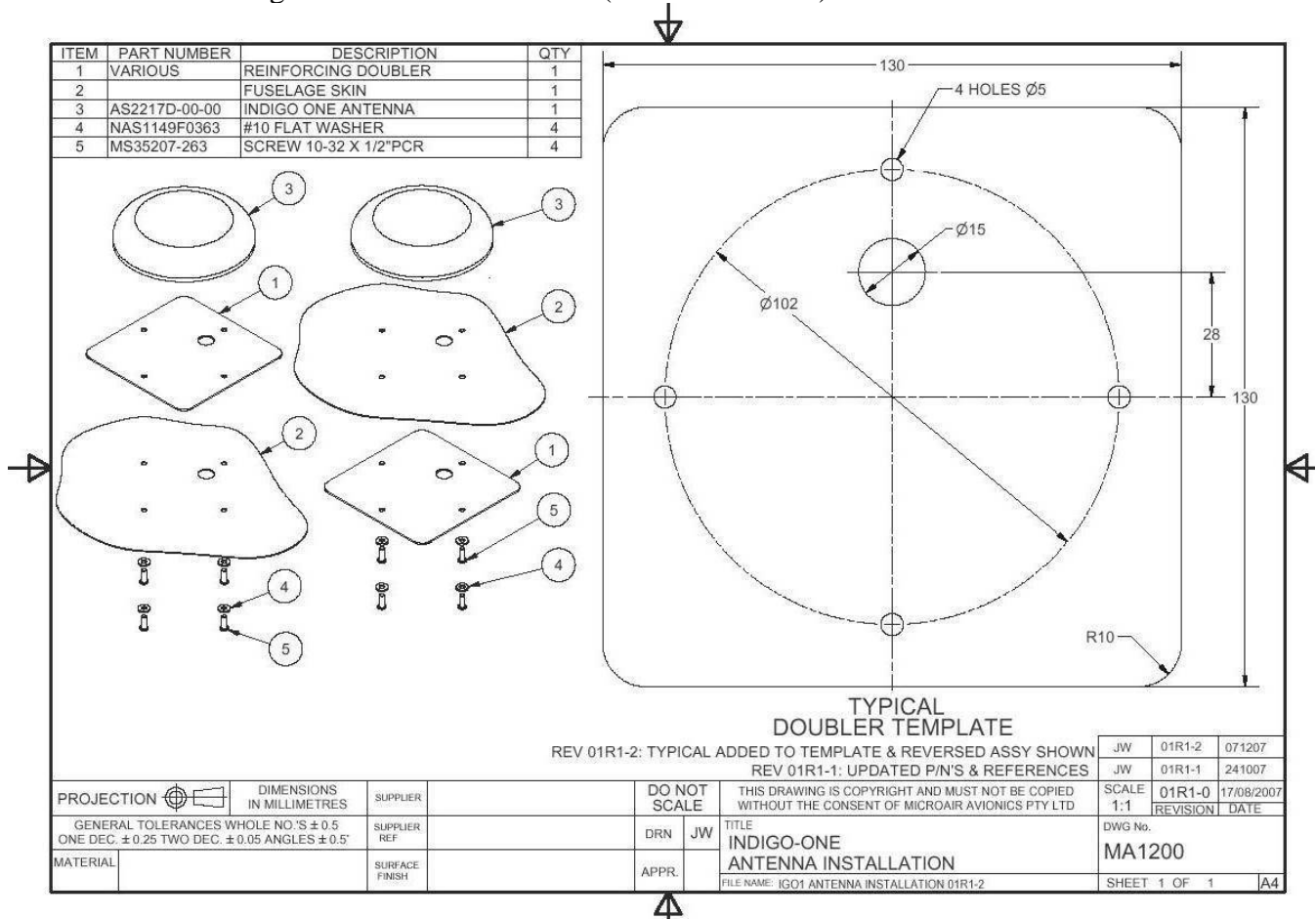

**Figure 3. Doubler details.**

PREPARED: N. Levchenko CHECKED: L. Ramirez ISSUE No.: One	<b>AERONAUTICAL ENGINEERS AUSTRALIA</b>	PAGE No.: Page 7 of 9 REPORT No.: AV13697.003/51 FILE: Installation Plan DHC-2.doc
<b>Installation Plan - Indigo One Tracking System – DHC-2 Beaver</b>		

### **3.2. Antenna Cable Routing**

The IndigoSat Installation Manual (IS-IM-2008-002) provides the general requirements for cable routing.

The coaxial cable should be run ensuring adequate fixing where possible to existing wiring looms. Attach to these existing wiring bundles by double tie-wrapping. Sufficient securing should be used to prevent any chaffing of the cable. Follow the normal wiring loom routing path of existing cable runs to run the coaxial cable to the selected control unit position determined in 2.2 above.

If the cable needs to pass through frames or bulkheads grommets should be used to prevent chafing or wear of the cable.

### **3.3. Wiring Harness Installation Procedure**

The IndigoSat Installation Manual (IS-IM-2008-002) provides the wiring harness installation procedure, including wiring diagram for the system installation.

If used, placard circuit breakers with function and rating. Text to be similar size and font to others on the panel.

Note that detailed connection of digital inputs should be determined by the installer in conjunction with the organisation approving the installation.

### **3.4. Install the Panel Control Unit**

Install the display unit to the location pre-selected in Section 2.2 in accordance with the details in the IndigoSat Installation Manual (IS-IM-2008-002).

## **4. FUNCTIONAL TESTING**

Carry out the Operation Configuration setup and Communications Testing in accordance with the IndigoSat Installation Manual (IS-IM-2008-002) to ensure correct function of the Indigo One system.

## 5. EMI / EMC TESTING

Conduct electrical interference checks of all aircraft systems with the Indigo One system operating to ensure that all systems are fully operational after installation. Force transmissions by sending a test message / alert message Conduct testing of each system in accordance with the manufacturer’s guidelines for that system. If required, testing may be done as part of a maintenance flight, and ongoing normal operation of the aircraft is dependant on successful completion of the testing. **Any observed interference is to be reported to the IndigoSat Operations Center.**

Indicate in the following table, whether any significant interference is observed:

Item	New System Incorporated	
	ON	OFF
NAV #1		
NAV #2		
ADF		
Autopilot		
HF		
VHF Com #1		
VHF Com #2		
DME		
Audio/Marker		
Transponder		
Weather Radar		
Rad Alt		
GPS		
Intercom System		
Engine instruments		
Magnetic compass		

When the aircraft system being evaluated is operated, there must be no standoff conditions displayed on any instruments. Generally, transient or flicker indications are not acceptable either. All observed interference is to be reported and all aural interference on avionics systems and intercom systems are to be reported.

VHF equipment will be operated and evaluated for interference to/from the new equipment by selecting VHF frequencies at 2MHz spacing between 118 and 136 MHz and verifying no objectionable interference is heard in the audio signals at any of the selected frequencies. All other systems are to be tested over their individual operating range.

Testing of aircraft with WAAS-based GPS systems require careful attention, as these are known to be highly sensitive to interference. Ensure that transmissions from the IndigoSat system do not interfere with GPS signal reception.

PREPARED: N. Levchenko CHECKED: L. Ramirez ISSUE No.: One	<b>AERONAUTICAL ENGINEERS AUSTRALIA</b>	PAGE No.: Page 9 of 9 REPORT No.: AV13697.003/51 FILE: Installation Plan DHC-2.doc
Installation Plan - Indigo One Tracking System – DHC-2 Beaver		

## 6. POST INSTALLATION

Carry out the post installation requirements detailed in the IndigoSat Installation Manual (IS-IM-2008-002).

## 7. USER MANUAL

A user manual is supplied with the kit which provides instructions on the functions available and how to operate the unit.

## 8. ONGOING AIRWORTHINESS

Refer to IndigoSat Installation Manual (IS-IM-2008-002) for ongoing airworthiness instructions.

## 9. STANDARD NOTES

- (1) All work to be conducted by an approved workshop using standard aircraft practices.
- (2) Fasteners used in avionics installations must be metal or nylon thread locked fasteners unless noted otherwise. Alternatively, Loctite 222 or 242 may be used on threads.
- (3) Unless otherwise noted, observe standard sheetmetal practices in accordance with AC43.13-1B Chapter 4. Section 4. Maintain a minimum fastener edge distance of 3d and a minimum fastener pitch of 4d. Material specifications as detailed below:
 

2024-T3 Alclad Sheet	QQ-A-250/5
----------------------	------------
- (4) All new unshielded wire to meet M22759/16 specifications. All new shielded wiring to meet MIL-C-27500. Wire gauge as indicated in the wiring diagram. All wiring to be in accordance with AC21.99.